



(19) **United States**

(12) **Patent Application Publication**
Park

(10) **Pub. No.: US 2004/0100191 A1**

(43) **Pub. Date: May 27, 2004**

(54) **ORGANIC ELECTROLUMINESCENT
DISPLAY PANEL DEVICE AND METHOD OF
FABRICATING THE SAME**

(52) **U.S. Cl. 313/506; 445/24**

(75) **Inventor: Jae-Yong Park, Gyeonggi-do (KR)**

(57) **ABSTRACT**

Correspondence Address:
MORGAN LEWIS & BOCKIUS LLP
1111 PENNSYLVANIA AVENUE NW
WASHINGTON, DC 20004 (US)

An organic electroluminescent device includes first and second substrates having pixel regions and a peripheral region, a first common electrode at the peripheral region on the first substrate, a driving thin film transistor (TFT) at each of the pixel regions on the first substrate, a first connection electrode connected to a drain electrode of the TFT, a second connection electrode connected to the first common electrode, a first electrode on the second substrate, isolating patterns on the first electrode corresponding to each border between the pixel regions, a first insulating pattern on the first electrode corresponding to the second connection electrode, partition walls on the isolating patterns, an organic luminescent layer on the first electrode, a second electrode on the organic luminescent layer connected to the first connection electrode at each of the pixel regions, and a first contacting electrode on the first insulating pattern contacting the first electrode.

(73) **Assignee: LG.Philips LCD Co., Ltd.**

(21) **Appl. No.: 10/716,438**

(22) **Filed: Nov. 20, 2003**

(30) **Foreign Application Priority Data**

Nov. 26, 2002 (KR) 2002-74012

Publication Classification

(51) **Int. Cl.⁷ H05B 33/00; H01J 9/00;
H01J 9/24**

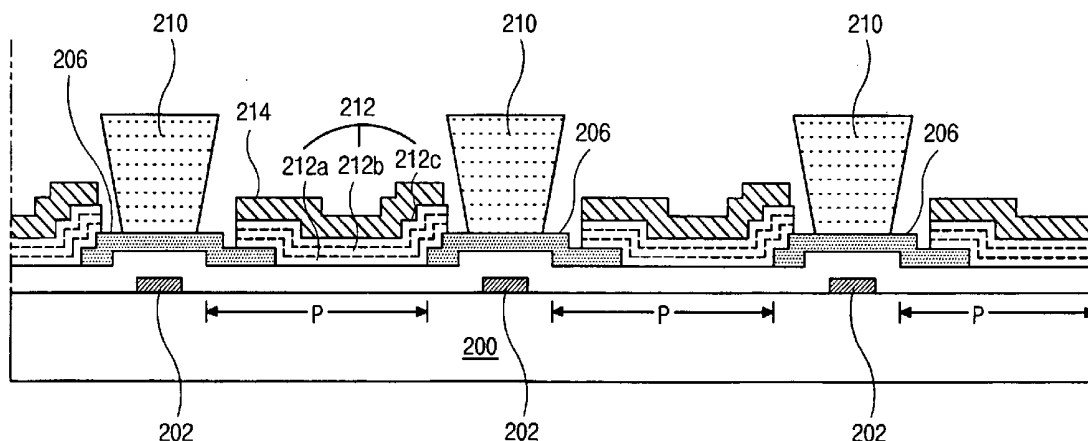

FIG. 2
RELATED ART

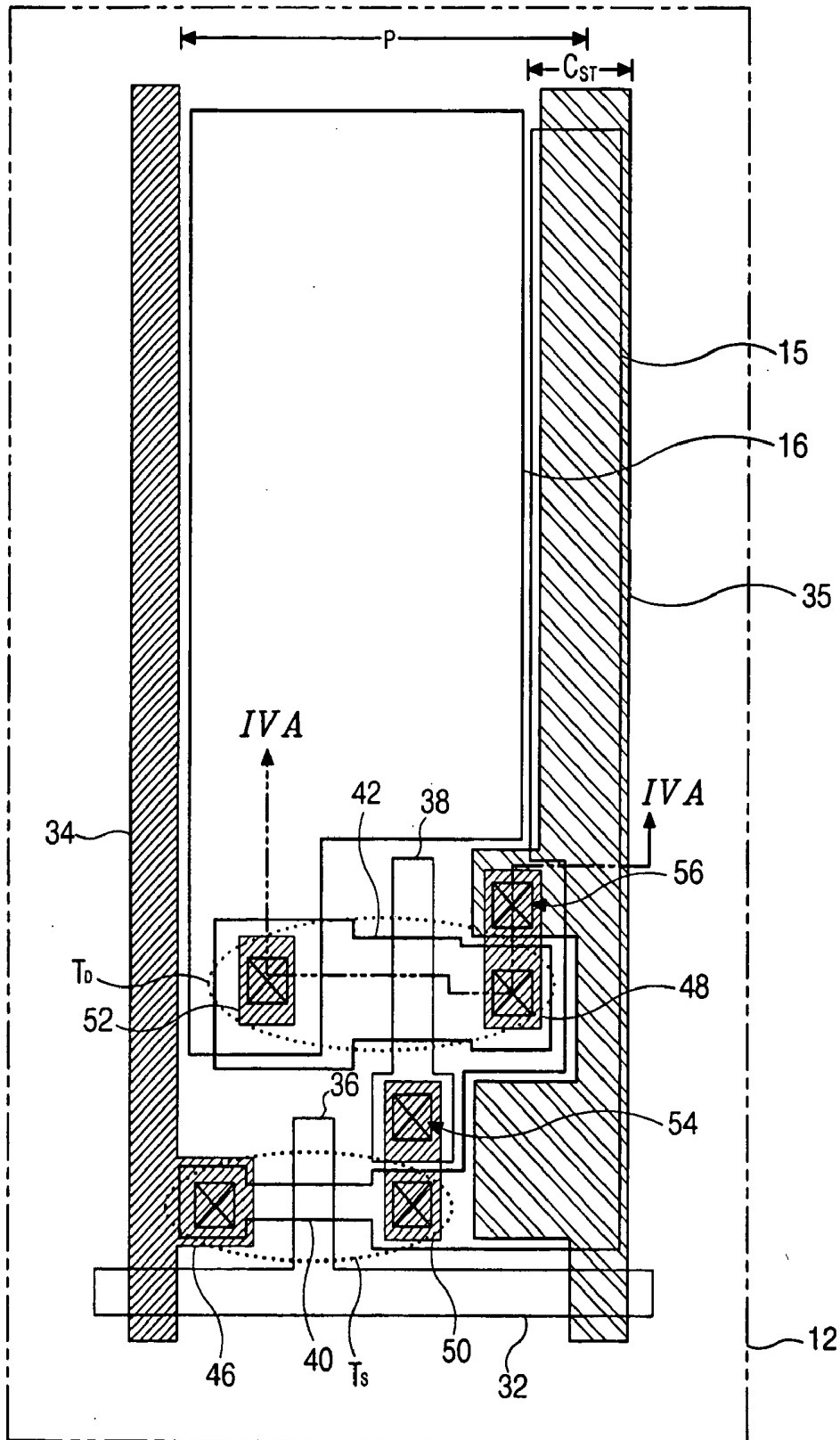

FIG. 3
RELATED ART

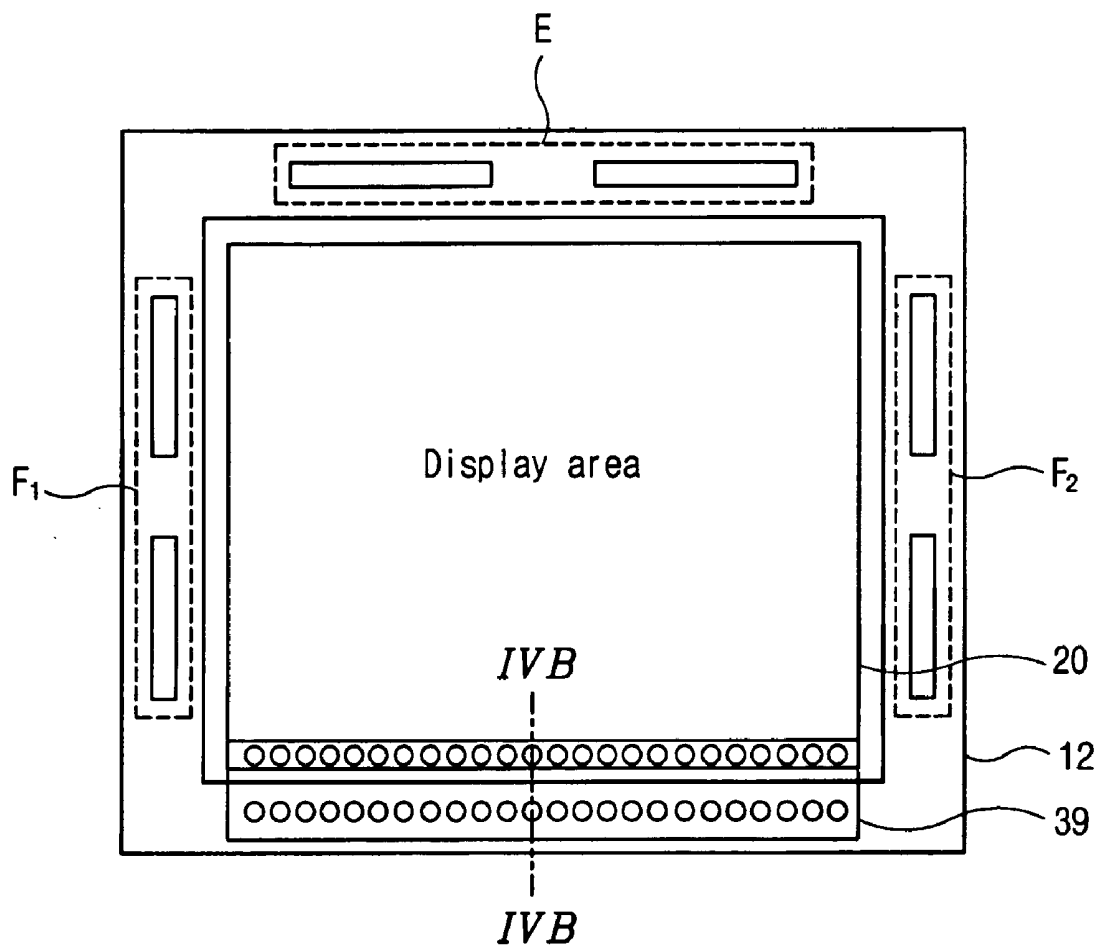

FIG. 4A
RELATED ART

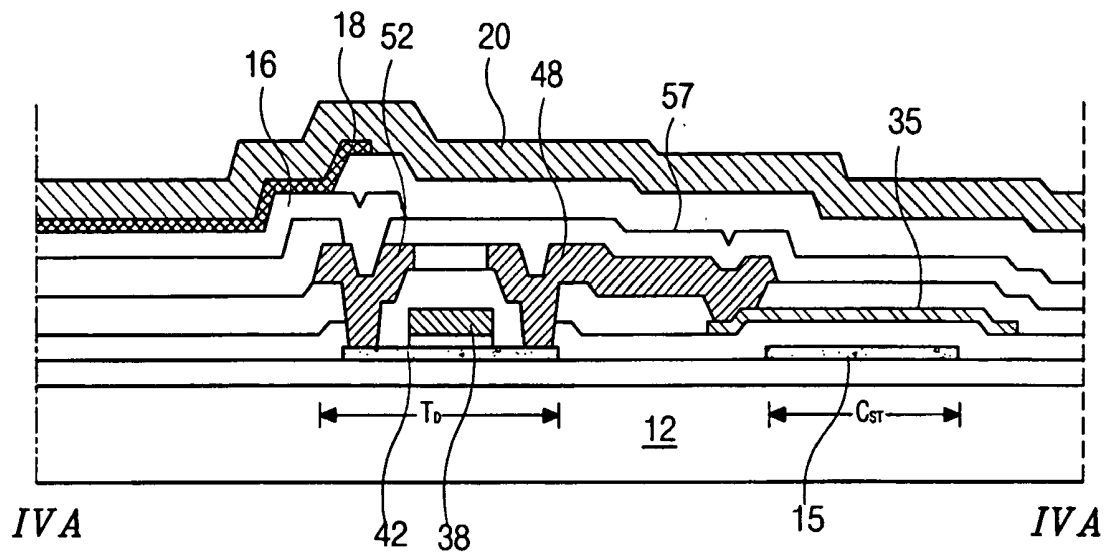

FIG. 4B
RELATED ART

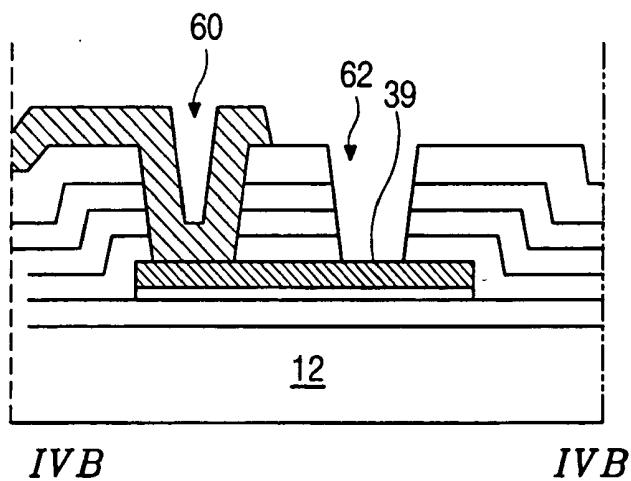

FIG. 5

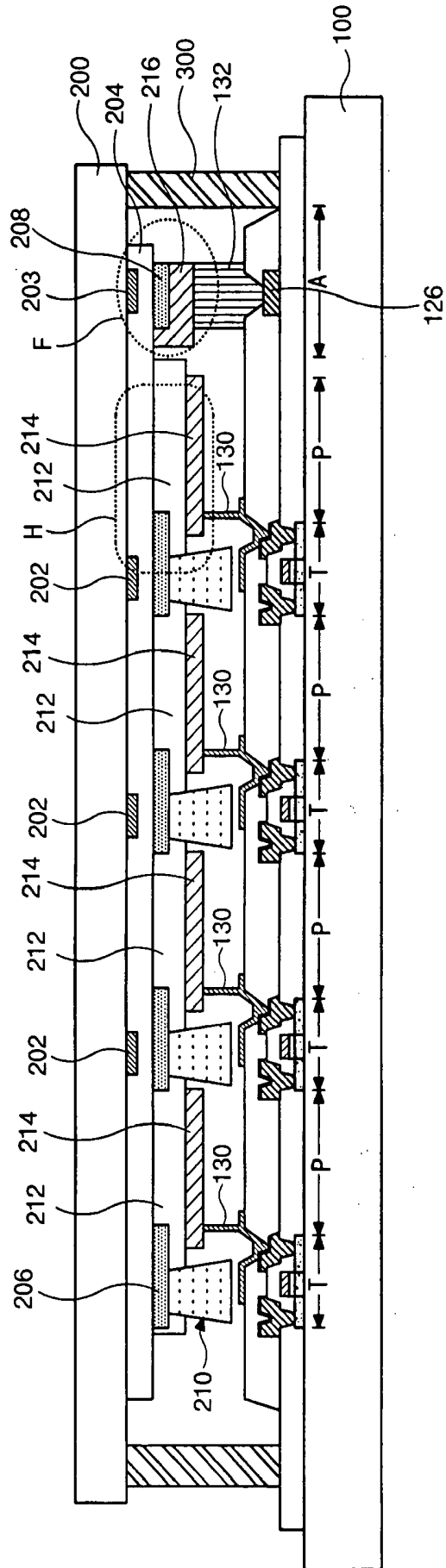

FIG. 6A

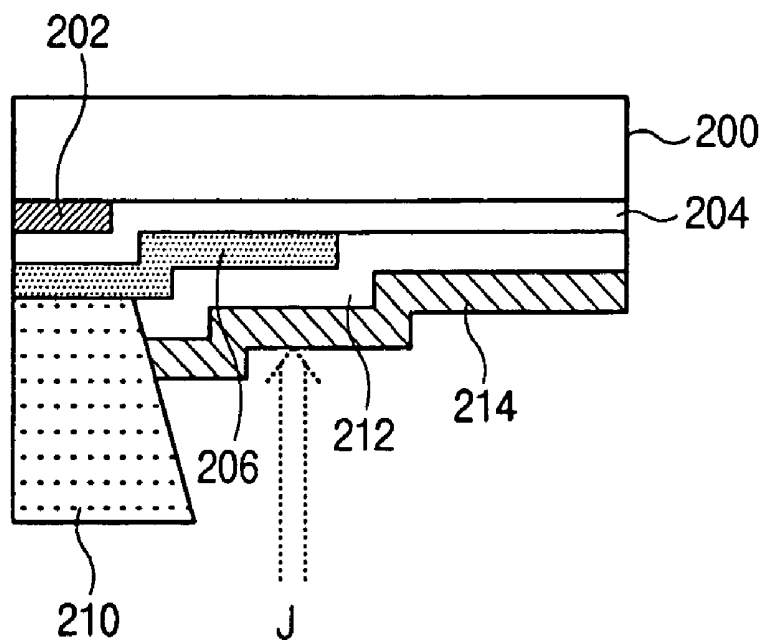

FIG. 6B

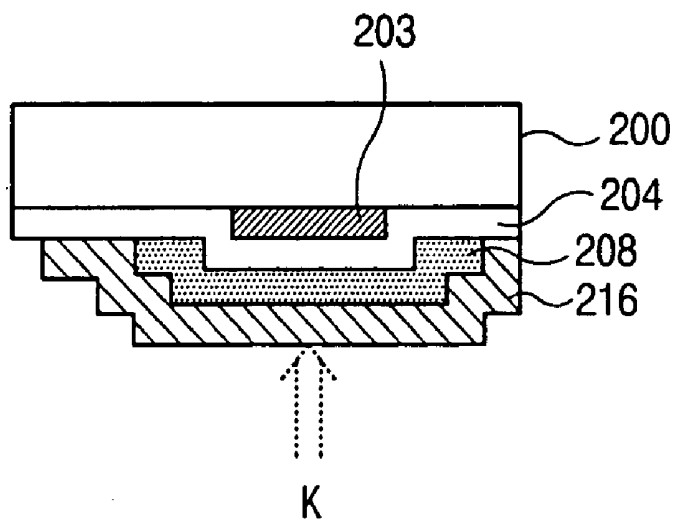

FIG. 7A

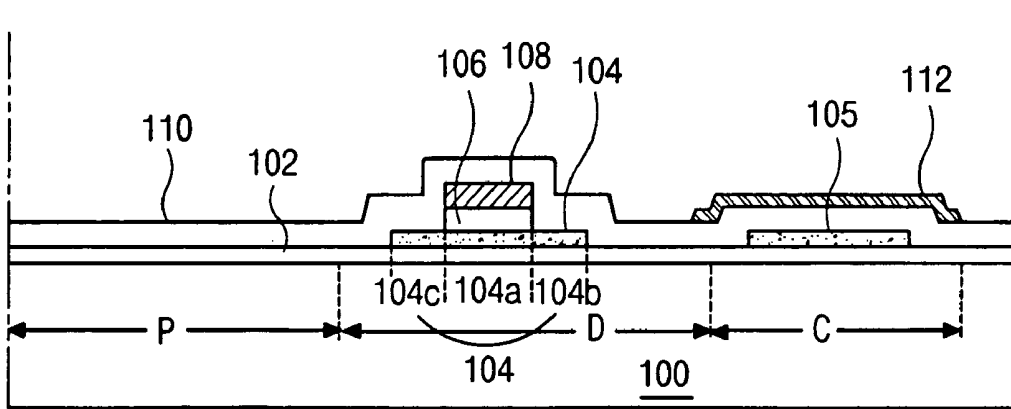

FIG. 7B

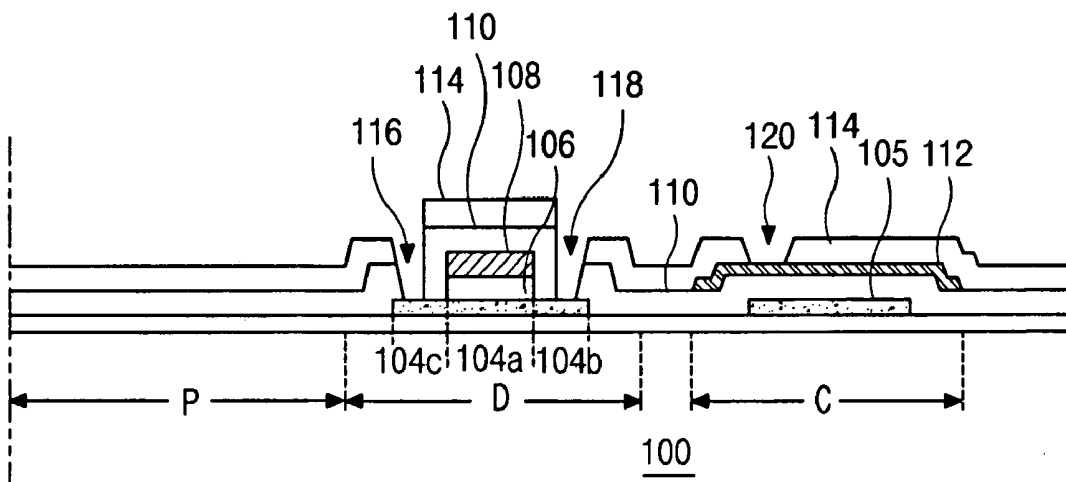

FIG. 7C

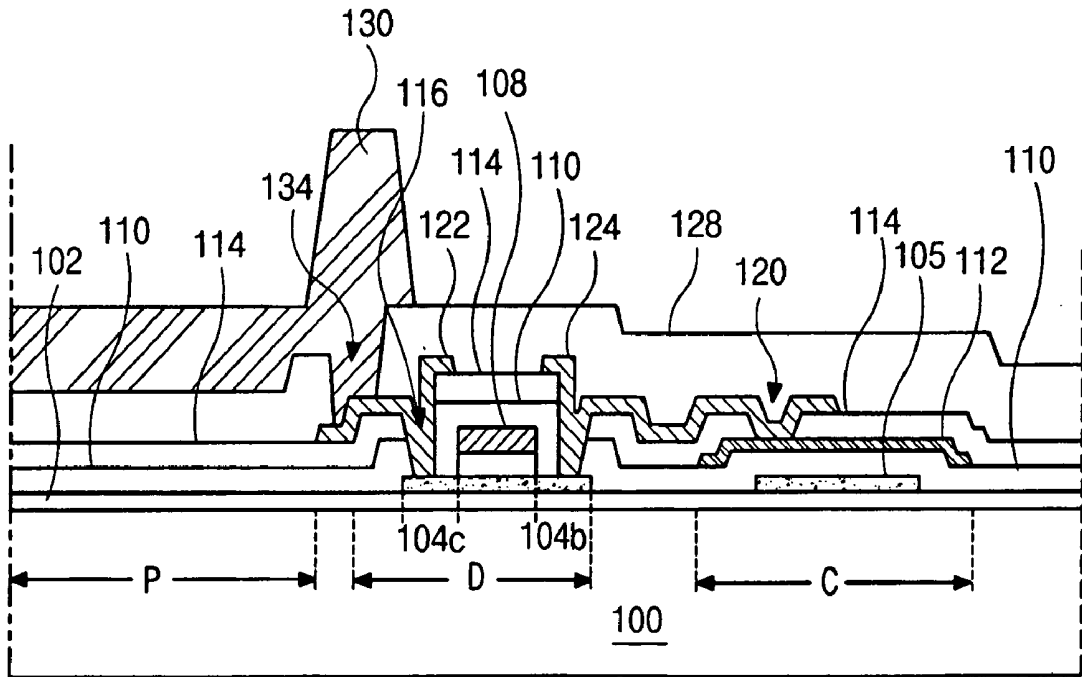

FIG. 8A

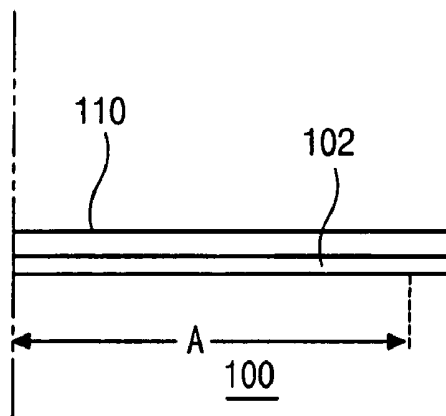

FIG. 8B

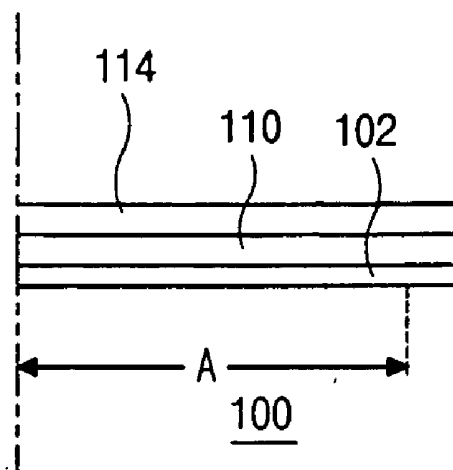

FIG. 8C

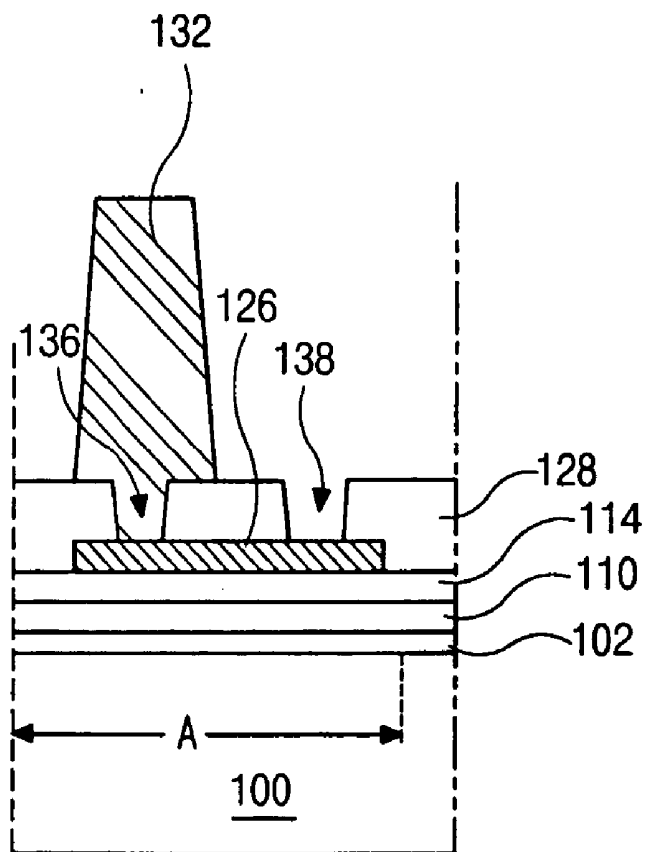

FIG. 9A

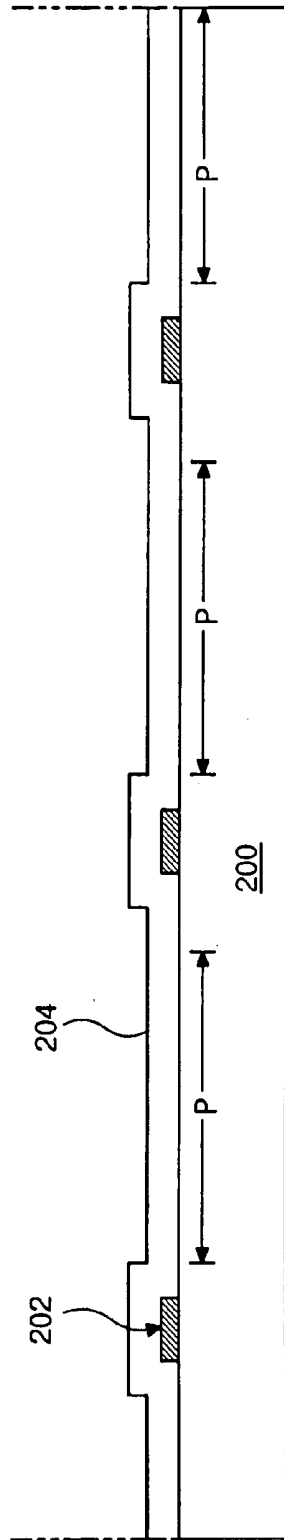

FIG. 9B

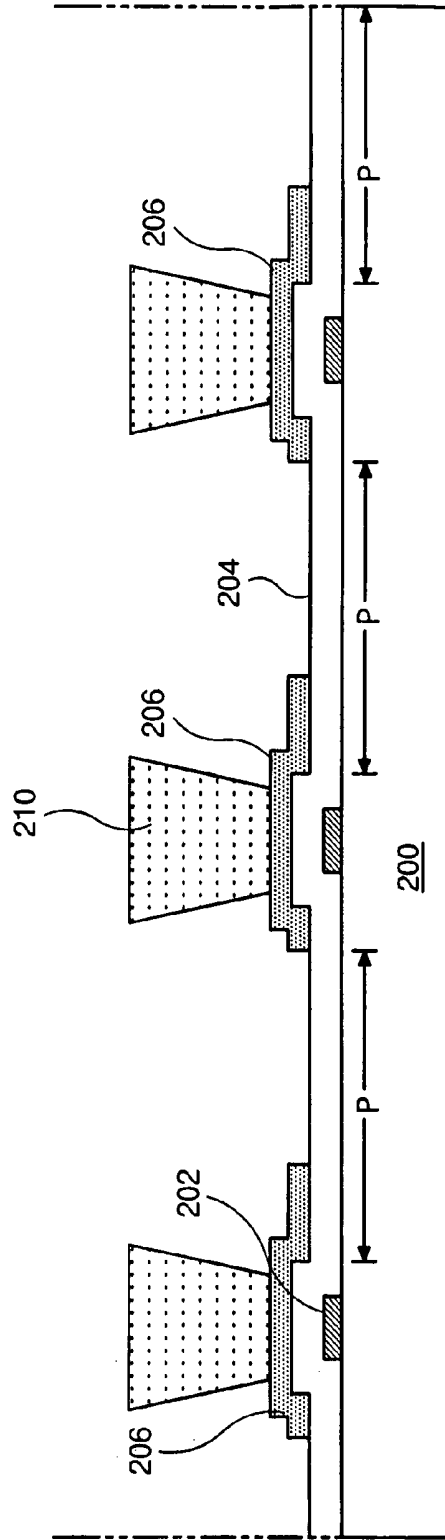

FIG. 9C

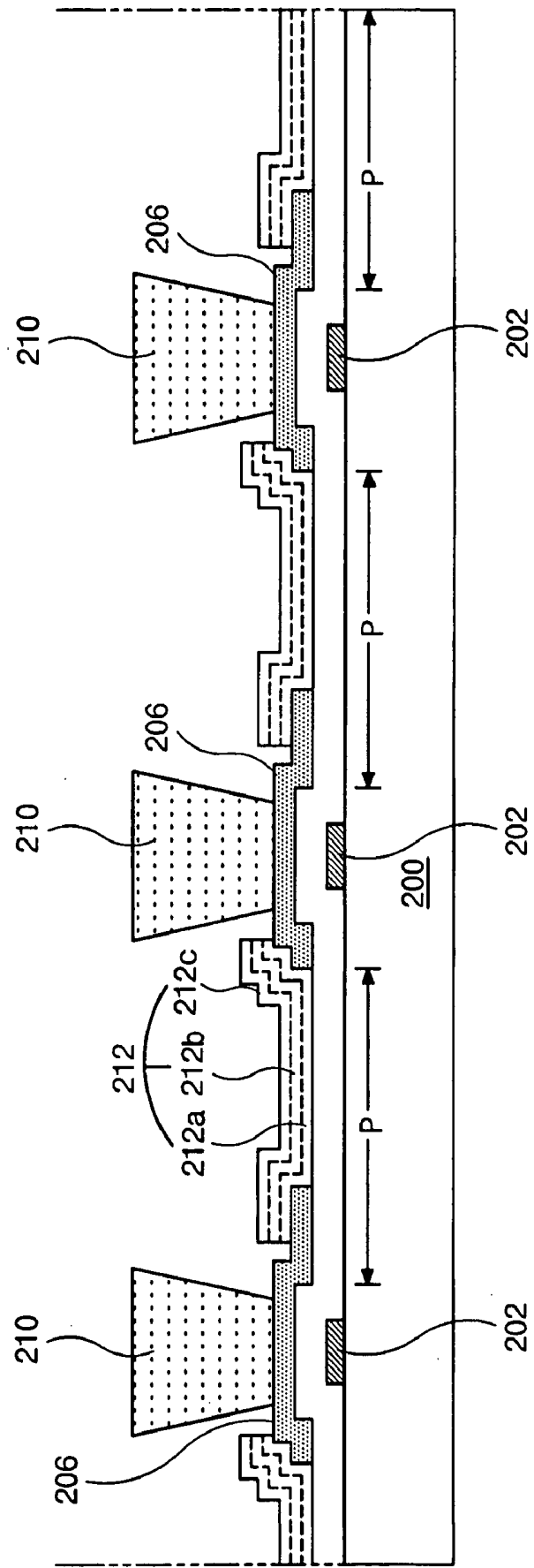

FIG. 9D

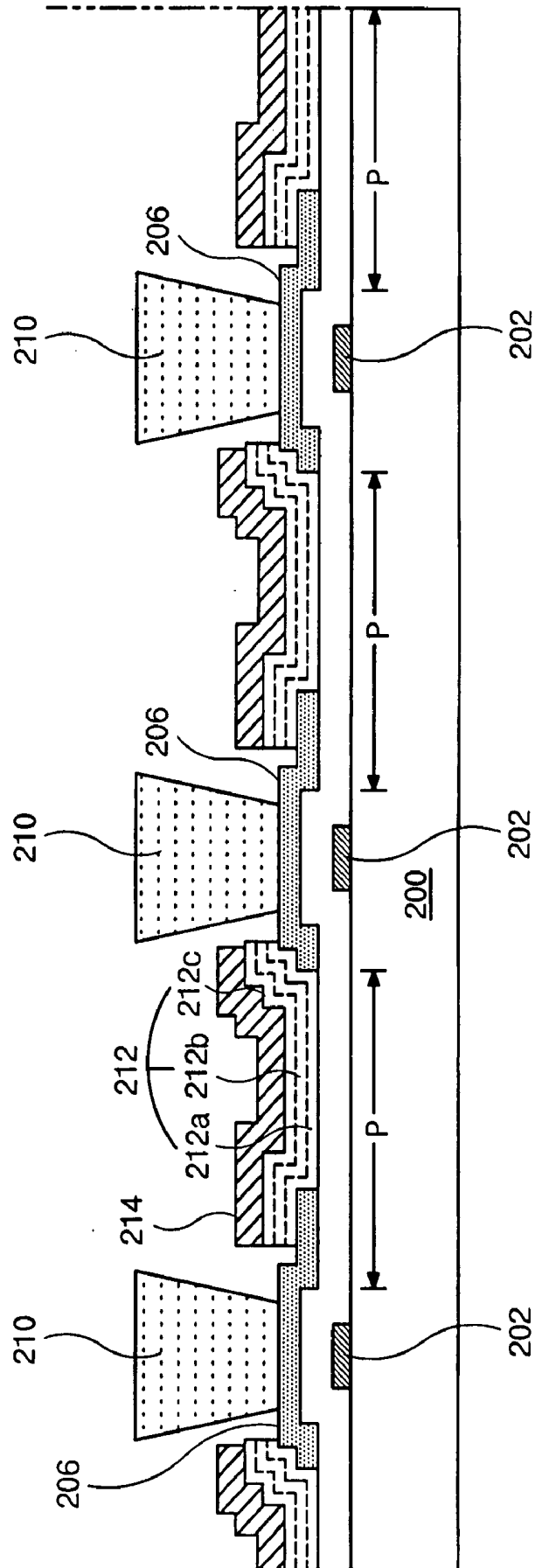

FIG. 10A

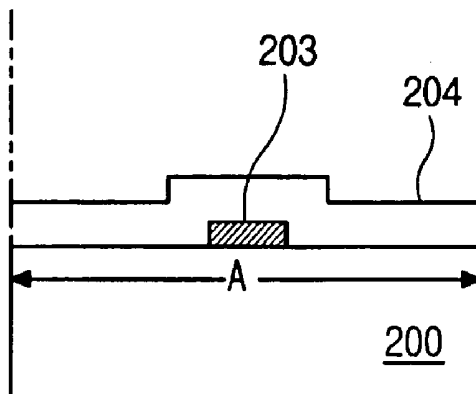

FIG. 10B

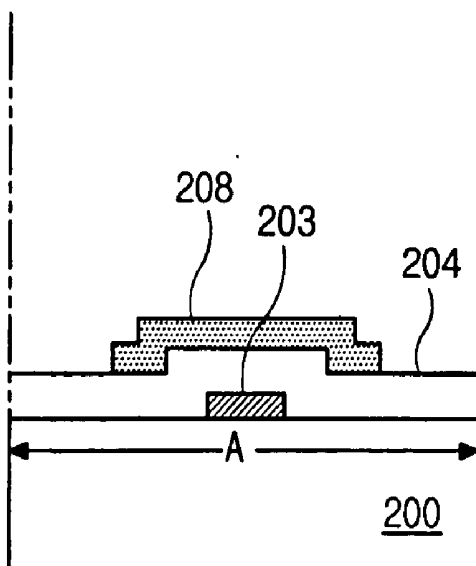

FIG. 10C

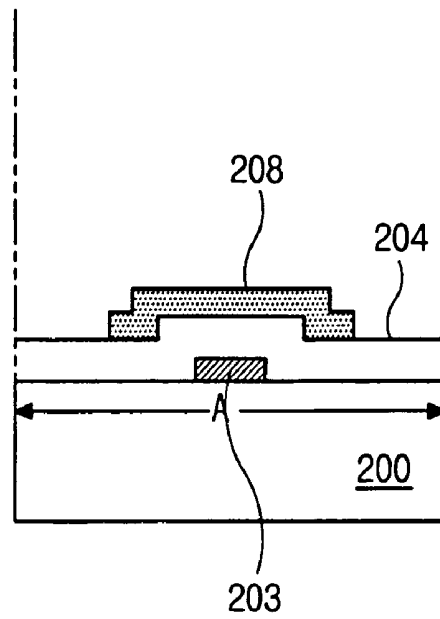

FIG. 10D

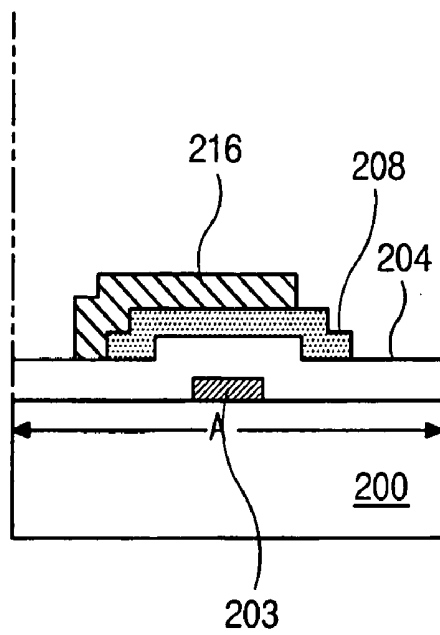
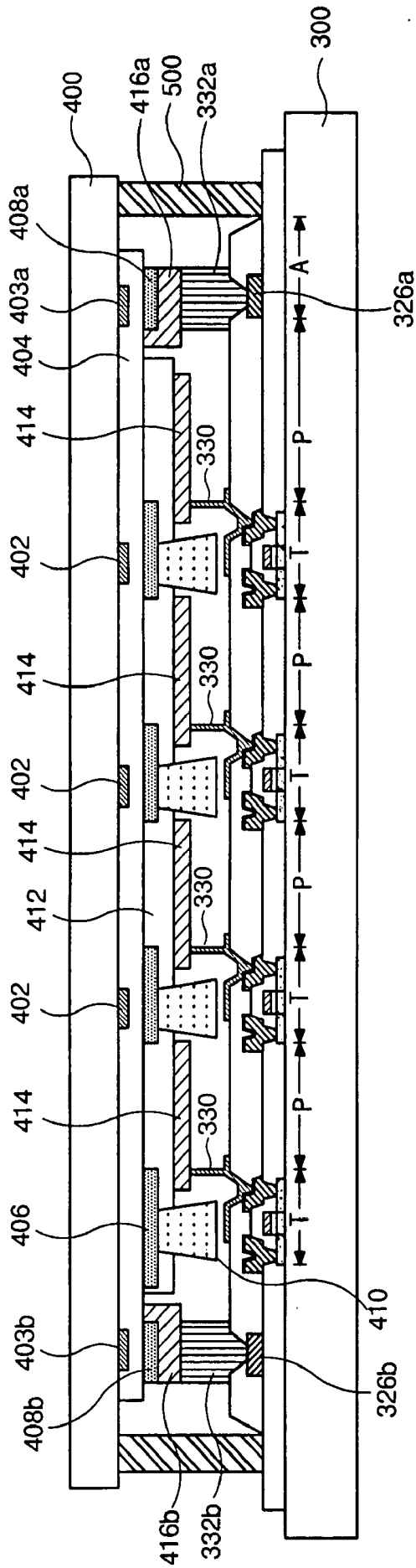

FIG. 11



ORGANIC ELECTROLUMINESCENT DISPLAY PANEL DEVICE AND METHOD OF FABRICATING THE SAME

[0001] The present invention claims the benefit of the Korean Patent Application No. P2002-074012 filed in Korea on Nov. 26, 2002, which is hereby incorporated by reference.

BACKGROUND OF THE INVENTION

[0002] 1. Field of the Invention

[0003] The present invention relates to an organic electroluminescent display panel device and method of fabricating the same, and more particularly, to an organic electroluminescent display panel device and a method of fabricating the same that has a high aperture ratio and high definition images.

[0004] 2. Discussion of the Related Art

[0005] In general, an organic electroluminescent device emits light by injecting electrons from a cathode electrode and holes from an anode electrode into an emissive layer, combining the electrons and the holes to generate an exciton, and transiting the exciton from an excited state to a ground state. Since the organic electroluminescent device is self-luminescent and does not require an additional light source, the organic electroluminescent device has a small size and is light weight, as compared to a liquid crystal display device. The organic electroluminescent device also has low power consumption, high brightness, and short response time. Thus, the organic electroluminescent device is used in many consumer electronics, such as cellular phones, car navigation systems (CNSs), personal digital assistants (PDAs), camcorders, and palm PCs. In addition, the organic electroluminescent device can have reduced manufacturing costs because of its simple manufacturing processes.

[0006] Organic electroluminescent devices may be categorized into passive matrix-type and active matrix-type depending upon how the device is driven. Compared to an active matrix-type, passive matrix-type organic electroluminescent devices have a simpler structure and are fabricated through a simpler manufacturing process. However, the passive matrix-type organic electroluminescent devices have higher power consumption, thereby preventing use in large area displays. Furthermore, in passive matrix organic electroluminescent devices, aperture ratio decreases according to the increasing number of electrical lines. Thus, the passive matrix-type organic electroluminescent devices are commonly used as small-sized display devices. In contrast, active matrix-type organic electroluminescent devices are commonly used as large-sized display devices since they have high luminous efficacy, and provide high definition images.

[0007] FIG. 1 is a cross sectional view of an organic electroluminescent display panel device according to the related art. In FIG. 1, the organic electroluminescent device 10 includes a first substrate 12 and a second substrate 28, that face each other with a predetermined space therebetween. A plurality of thin film transistors T and a plurality of first electrodes 16 are formed on an inner surface of the first substrate 12, wherein each of the first electrodes 16 are connected to each of the thin film transistors T, respectively. In addition, organic luminescent layers 18 are formed on the

first electrodes 16 and the thin film transistors T, and a second electrode 20 is formed on the organic luminescent layers 18. The organic luminescent layers 18 emit light in one of three colors: red (R), green (G), and blue (B) within a pixel region P, and are generally formed by patterning an organic material.

[0008] A desiccant 22 is formed on an inner surface of the second substrate 28 to remove any external moisture and air that may permeate into a space between the first and second substrates 12 and 28. The inner surface of the second substrate 28 is patterned to form a groove, and the desiccant 22 is disposed within the groove and is fastened with a tape 25.

[0009] A sealant 26 is formed between the first and second substrates 12 and 28, and surrounds array elements, such as the thin film transistors T, the first electrodes 16, the organic luminescent layers 18, and the second electrodes 20. The sealant 26 attaches the first and second substrates 12 and 28 together and forms an airtight space to protect the elements from the external moisture and air.

[0010] FIG. 2 is a plane view of a pixel of the organic electroluminescent display panel device of FIG. 1. In FIG. 2, the pixel includes a switching thin film transistor (TFT) T_S , a driving thin film transistor (TFT) T_D , and a storage capacitor C_{ST} . In addition, a gate line 32 and a data line 34 are formed on the first substrate 12, and are formed of a transparent material, such as glass and plastic. The gate line 32 and the data line 34 cross each other, thereby defining the pixel region P, and a power line 35 is formed parallel to the data line 34.

[0011] The switching TFT T_S includes a gate electrode 36, an active layer 40, a source electrode 46, and a drain electrode 50. The driving TFT T_D includes a gate electrode 38, an active layer 42, a source electrode 48, and a drain electrode 52. In particular, the gate electrode 36 of the switching TFT T_S connects to the gate line 32, and the source electrode 46 of the switching TFT T_S connects to the data line 34. The drain electrode 50 of the switching TFT T_S connects to the gate electrode 38 of the driving TFT T_D through a first contact hole 54, and the source electrode 48 of the driving TFT T_D connects to the power line 35 through a second contact hole 56. The drain electrode 52 of the driving TFT T_D connects to the first electrode 16 in the pixel region P. A capacitor electrode 15 overlaps the power line 35 to form the storage capacitor C_{ST} , and is made of doped polycrystalline silicon and connects to the drain electrode 50 of the switching TFT T_S .

[0012] FIG. 3 is a layout of the organic electroluminescent display panel device of FIG. 1. In FIG. 3, a display area is defined in a central region of the first substrate 12. A data pad portion E is formed in an upper side of the first substrate 12, and a first gate pad portion F1 and a second gate pad portion F2 are formed in left and right sides of the first substrate 12, respectively. A common electrode 39 is formed in a lower side of the substrate 12. The common electrode 39 applies a common voltage to the second electrode 20, which functions as a cathode electrode and is formed over the display area, and maintains the common voltage.

[0013] FIG. 4A is a cross sectional view along IVA-IVA of FIG. 2. In FIG. 4A, the driving TFT T_D is formed on the substrate 12, and includes the gate electrode 38, the active

layer **42**, and the source and drain electrodes **48** and **52**. The storage capacitor C_{ST} is formed over the substrate **12** and is parallel connected to the driving TFT T_D . The storage capacitor C_{ST} includes the capacitor electrode **15** and the power line **35**, which function as a first capacitor electrode and a second capacitor electrode, respectively. The capacitor electrode **15** is made of polycrystalline silicon. An insulating layer **57** covers the driving TFT T_D and the storage capacitor C_{ST} , and the first electrode **16** is formed on the insulating layer **57** to electrically contact the drain electrode **52**. An organic luminescent layer **18** that emits one color of light is formed on the first electrode **16**, and the second electrode **20** is formed on the organic layer **18**.

[0014] FIG. 4B is a cross sectional view along IVB-IVB of FIG. 3. In FIG. 4B, the common electrode **39** is formed in a side of the substrate **12** to apply a common voltage to the second electrode **20** (FIG. 4A). The common electrode **39** may be made of the same material as the gate electrode **38** of the driving TFT T_D (FIG. 4A). The common electrode **39** is exposed by a first common contact hole **60** and a second common contact hole **62** through insulating layers. The second electrode **20** connects to the common electrode **39**. An input line (not shown) from the outside could connect to the common electrode **39** through the second common contact hole **62**.

[0015] A yield of the organic electroluminescent device depends on yields of the thin film transistor and the organic layer. Especially, the yield of the organic electroluminescent device varies due to impurities in the process of forming the organic layer to a thickness of about 1,000 Å. Accordingly, the yield of the organic electroluminescent device of the related art is reduced because of the impurities, thereby resulting in a loss of manufacturing costs and source materials for the thin film transistor.

[0016] Moreover, the organic electroluminescent device of the related art is a bottom emission mode device having stability and degrees of freedom for the manufacturing processes. However, the bottom emission mode device has a reduced aperture ratio. Thus, the bottom emission mode organic electroluminescent device has difficulty in being used as a high aperture device.

[0017] On the other hand, a top emission mode organic electroluminescent device has a high aperture ratio, and is easy to manufacture. However, in the top emission mode organic electroluminescent device, since a cathode electrode is generally disposed over the organic layer, a choice of material with which to make the cathode electrode is limited. Accordingly, transmittance of light is limited, and a luminous efficacy is reduced. Furthermore, in order to improve light transmittance the passivation layer should be formed as a thin film, whereby the exterior moisture and air is not fully blocked.

SUMMARY OF THE INVENTION

[0018] Accordingly, the present invention is directed to an organic electroluminescent display panel device and a method of fabricating the same that substantially obviate one or more of the problems due to limitations and disadvantages of the related art.

[0019] An object of the present invention is to provide an organic electroluminescent display panel device and a method of fabricating the same having a high aperture ratio and high definition images.

[0020] Another object of the present invention is to provide an organic electroluminescent display panel device and a method of fabricating the same having an improved yield and productivity.

[0021] Another object of the present invention is to provide an organic electroluminescent display panel device and a method of fabricating the same that are reliable.

[0022] Additional features and advantages of the invention will be set forth in the description which follows and in part will be apparent from the description, or may be learned by practice of the invention. The objectives and other advantages of the invention will be realized and attained by the structure particularly pointed out in the written description and claims hereof as well as the appended drawings.

[0023] To achieve these and other advantages and in accordance with the purpose of the present invention, as embodied and broadly described, the organic electroluminescent device includes first and second substrates facing and spaced apart from each other, the first and second substrates having a display area including a plurality of pixel regions and a first peripheral region at one side of the display area, a first common electrode at the first peripheral region on an inner surface of the first substrate, a driving thin film transistor at each of the pixel regions on the inner surface of the first substrate, the driving thin film transistor including an active layer, a gate electrode, and source and drain electrodes, a first connection electrode connected to the drain electrode of the driving thin film transistor at each of the pixel regions, a second connection electrode connected to the first common electrode at the first peripheral region, a first electrode on an entire inner surface of the second substrate, isolating patterns on the first electrode corresponding to each border between the pixel regions, a first insulating pattern at the first peripheral region on the first electrode corresponding to the second connection electrode, partition walls on the isolating patterns, an organic luminescent layer at each of the pixel regions on the first electrode, a second electrode on the organic luminescent layer connected to the first connection electrode at each of the pixel regions, a first contacting electrode on the first insulating pattern contacting the first electrode, and a sealant attaching the first and second substrates.

[0024] In another aspect, the method of fabricating an organic electroluminescent device includes forming an insulating layer on a first substrate having a display area including a plurality of pixel regions and a first peripheral region at one side of the display area, forming a driving thin film transistor at each of the plurality of pixel regions on the insulating layer, the driving thin film transistor including an active layer, a gate electrode, and source and drain electrodes, forming a first common electrode at the first peripheral region on the insulating layer, forming a first connection electrode and a second connection electrode, the first connection electrode connected to the drain electrode, the second connection electrode connected to the first common electrode, forming a first electrode on a second substrate, forming isolating patterns and a first insulating pattern on the first electrode, the isolating patterns corresponding to each border between the pixel regions, the first insulating pattern at the first peripheral region, forming partition walls on the isolating patterns, forming an organic luminescent layer at each of the plurality of pixel regions on the first

electrode, forming a second electrode on the organic luminescent layer, forming a first contacting electrode on the first insulating pattern and contacting the first electrode, and attaching the first and second substrates with a sealant such that the first connection electrode contacts the second electrode and the second connection electrode contacts the first contacting electrode.

[0025] In another aspect, the method of fabricating an organic electroluminescent device includes forming a first insulating layer on a first substrate having a display area including a plurality of pixel regions and a first peripheral region at one side of the display area, forming an active layer on the first insulating layer at each of the plurality of pixel regions, the active layer including polycrystalline silicon, the active layer having source and drain regions, forming a second insulating layer on the active layer, forming a gate electrode on the second insulating layer over the active layer, forming a third insulating layer on the gate electrode, the third insulating layer having first and second contact holes, the first contact hole exposing the source region, the second contact hole exposing the drain region, forming source and drain electrodes and a first common electrode on the third insulating layer, the source electrode being connected to the source region through the first contact hole, the drain electrode connected to the drain region through the second electrode, the first common electrode disposed at the peripheral region, forming a fourth insulating layer on the source and drain electrodes and the first common electrode, the fourth insulating layer having third, fourth and fifth contact holes, the third contact hole exposing the drain electrode, the fourth and fifth contact holes exposing the first common electrode, forming first and second connection electrodes on the fourth insulating layer, the first connection pattern connected to the drain electrode through third contact hole, the second connection electrode connected to the first common electrode through the fourth contact hole, forming a first electrode on a second substrate, forming isolating patterns and a first insulating pattern on the first electrode, the isolating patterns corresponding to each border between the pixel regions, the first insulating pattern at the first peripheral region, forming partition walls on the isolating patterns, forming an organic luminescent layer at each of the plurality of pixel regions on the first electrode, forming a second electrode on the organic luminescent layer, forming a first contacting electrode on the first insulating pattern and contacting the first electrode, and attaching the first and second substrates with a sealant such that the first connection electrode contacts the second electrode and the second connection electrode contacts the first contacting electrode.

[0026] It is to be understood that both the foregoing general description and the following detailed description are exemplary and explanatory and are intended to provide further explanation of the invention as claimed.

BRIEF DESCRIPTION OF THE DRAWINGS

[0027] The accompanying drawings, which are included to provide a further understanding of the invention and are incorporated in and constitute a part of this application, illustrate embodiments of the invention and together with the description serve to explain the principle of the invention. In the drawings:

[0028] FIG. 1 is a cross sectional view of an organic electroluminescent display panel device according to the related art;

[0029] FIG. 2 is a plane view of a pixel of the organic electroluminescent display panel device of FIG. 1;

[0030] FIG. 3 is a layout of the organic electroluminescent display panel device of FIG. 1;

[0031] FIG. 4A is a cross sectional view along IVA-IVA of FIG. 2;

[0032] FIG. 4B is a cross sectional view along IVB-IVB of FIG. 3;

[0033] FIG. 5 is a cross sectional view of an exemplary organic electroluminescent display panel device according to the present invention;

[0034] FIG. 6A is a cross sectional view of region H of FIG. 5;

[0035] FIG. 6B is a cross sectional view of region I of FIG. 5;

[0036] FIGS. 7A to 7C are cross-sectional views showing an exemplary fabricating process for a pixel region of a first substrate for an organic electroluminescent device according to the present invention;

[0037] FIGS. 8A to 8C are cross-sectional views showing an exemplary fabricating process for a peripheral region of the first substrate for an organic electroluminescent device according to the present invention;

[0038] FIGS. 9A to 9D are cross-sectional views showing an exemplary fabricating process for a display area of a second substrate for an organic electroluminescent device according to the present invention;

[0039] FIGS. 10A to 10D are cross-sectional views showing an exemplary fabricating process for a peripheral region of the second substrate for an organic electroluminescent device according to the present invention; and

[0040] FIG. 11 is a cross-sectional view showing another exemplary organic electroluminescent device according to the present invention.

DETAILED DESCRIPTION OF THE PREFERRED EMBODIMENTS

[0041] Reference will now be made in detail to the preferred embodiments of the present invention, an example of which is illustrated in the accompanying drawings.

[0042] FIG. 5 is a cross sectional view of an exemplary organic electroluminescent display panel device according to the present invention. In FIG. 5, the organic electroluminescent device may include a first substrate 100 and a second substrate 200 that are spaced apart and face each other. A sealant 300 may be used to attach the first and second substrates 100 and 200 together. The first and second substrates 100 and 200 may include a plurality of pixel regions P, which constitute a display area, and a peripheral region A, which is disposed at a side of the display area. In addition, a plurality of thin film transistors T may be formed on an inner surface of the first substrate 100 adjacent to the plurality of pixel regions P, respectively, wherein the thin film transistor T may function as a driving thin film transistor of the organic electroluminescent device. Although not shown, a plurality of switching thin film transistors and array lines also may be formed on the inner surface of the first substrate 100.

[0043] A plurality of first auxiliary electrodes **202** may be formed on an inner surface of the second substrate **200** and a first electrode **204** may be formed on the entire inner surface of the second substrate **200** covering the first auxiliary electrodes **202**. The first electrode **204** may function as an anode for injecting holes, and may receive a common voltage. In addition, a plurality of isolating patterns **206** may be formed on the first electrode **204** by depositing and patterning an insulating material. Further, a plurality of partition walls **210** may be formed on the plurality of isolating patterns **206**, such that the isolating patterns **206** and the partition walls **210** correspond to borders between the pixel regions P. Between the adjacent partition walls **210**, a plurality of organic luminescent layers **212** and a plurality of second electrodes **214** may be subsequently formed on the first electrode **204**. The plurality of second electrodes **214** may function as a cathode for injecting electrons. Each of the second electrodes **214** may be electrically connected to each of the thin film transistors T through a first connection electrode **130**. The first connection electrodes **130** may be first formed on the inner surface of the first substrate **100**, and the first substrate **100** may then be attached to the second substrate **200** by the sealant **300**, such that the first connection electrodes **130** contact the second electrodes **214**, respectively.

[0044] In addition, a common electrode **126** may be formed over the inner surface of the first substrate **100** in the peripheral region A. A second auxiliary electrode **203** may be formed on the inner surface of the second substrate **200** in the peripheral region A before forming the first electrode **204**, such that the first electrode **204** covers the second auxiliary electrode **203**. The second auxiliary electrode **203** may be made of a same material as the first auxiliary electrodes **202**. Further, an insulating pattern **208** may be formed on the first electrode **204** over the second auxiliary electrode **203**, and a contacting electrode **216** may be formed on the insulating pattern **208** to be directly connected to the first electrode **204**. The insulating pattern **208** may be made of a same material as the isolating pattern **206**, and may be simultaneously formed during the process of forming the isolating pattern **206**. Also, the contacting electrode **216** may be made of a same material as the second electrode **214**, and may be simultaneously formed during the process of forming the second electrodes **214**. The contacting electrode **216** may electrically connect to the common electrode **126** through a second connection electrode **132**.

[0045] Accordingly, the first and second connection electrodes **130** and **132** maintain uniform gaps both in the pixel regions P and the peripheral region A, thereby preventing the common voltage being poorly applied to the first electrode **204** through the second connecting electrode **132**.

[0046] FIG. 6A is a cross sectional view of region H of FIG. 5, and FIG. 6B is a cross sectional view of region I of FIG. 5. In FIG. 6A, the first auxiliary electrode **202**, the first electrode **204**, the isolating pattern **206**, the partition wall **210**, the organic luminescent layer **212** and the second electrode **214** are formed on the inner surface of the second substrate **200**. A first portion J, where the first connecting electrode **130** of FIG. 5 would contact the second substrate **200**, may include only the first electrode **204**, the isolating pattern **206**, the organic luminescent layer **212** and the second electrode **214**. In FIG. 6B, a second portion K, where the second connecting electrode **132** of FIG. 5 would

contact the second substrate **200**, may include only the second auxiliary electrode **203**, the first electrode **204**, the insulating pattern **208**, and the contact electrode **216**. The first and second auxiliary electrodes **202** and **203** may have a thickness within a range of about 500 Å to 3,000 Å. The first electrode **204** may have a thickness within a range of about 1,000 Å to 2,000 Å. The isolating pattern **206** and the insulating pattern **208** may have a thickness within a range of about 500 Å to 3,000 Å. The organic luminescent layer **212** may have a thickness within a range of about 1,000 Å to 2,000 Å, and the second electrode **214** and the contact electrode **216** may have a thickness within a range of about 500 Å to 3,000 Å. Accordingly, the layers of the first portion J may have a first thickness within a range of about 3,000 Å to 10,000 Å and the layers of the second portion K may have a second thickness within a range of about 2,500 to 11,000 Å. Thus, the first thickness and the second thickness may be similar to each other.

[0047] FIGS. 7A to 7C are cross-sectional views showing an exemplary fabricating process for a pixel region of a first substrate for an organic electroluminescent device according to the present invention. FIGS. 8A to 8C are cross-sectional views showing an exemplary fabricating process for a peripheral region of the first substrate for an organic electroluminescent device according to the present invention. In particular, FIGS. 7A to 7C may correspond to cross-sections along IVA-IVA of FIG. 2, and FIGS. 8A to 8C correspond to cross-sections along IVB-IVB of FIG. 3. In FIGS. 7A and 8A, a first substrate **100** may include a pixel region P, a driving region D, a storage region C and a peripheral region A. A buffer layer **102** may be formed on an entire surface of the first substrate **100** as a first insulating layer by depositing one of silicon nitride (SiN_x) and silicon oxide (SiO_2). A polycrystalline pattern **104** and a second polycrystalline pattern **105** of polycrystalline silicon may be formed on the buffer layer **102** within the driving and storage regions D and C, respectively. For example, the first and second polycrystalline patterns **104** and **105** can be formed through a dehydrogenation process and a crystallization process using a heat after deposition of amorphous silicon. The second polycrystalline pattern **105** may function as a first electrode of a storage capacitor by doping with impurities. A gate insulating layer **106** as a second insulating layer and a gate electrode **108** may be sequentially formed on a central portion of the first polycrystalline pattern **104**. The gate insulating layer **106** may be formed on the entire surface of the first substrate **100**, and may be made of one of silicon nitride (SiN_x) and silicon oxide (SiO_2).

[0048] After forming the gate electrode **108**, the first polycrystalline pattern **104** may be doped with impurities such as boron (B) or phosphorus (P) to define a channel region **104a** corresponding to the gate electrode **108**, and source and drain regions **104b** and **104c** at both sides of the channel region **104a**. The second polycrystalline pattern **105** also may be doped with the impurities. The gate electrode **108** may be formed of one of aluminum (Al), aluminum (Al) alloy, copper (Cu), tungsten (W), tantalum (Ta) and molybdenum (Mo). An interlayer insulating layer **110** as a third insulating layer may be formed on the entire surface of the first substrate **100** covering the gate electrode **108**. The interlayer insulating layer **110** may be formed of one silicon nitride (SiN_x) and silicon oxide (SiO_2). A capacitor electrode **112** may be formed on the interlayer insulating layer **110** within the storage region C by depositing and patterning one

of aluminum (Al), aluminum (Al) alloy, copper (Cu), tungsten (W), tantalum (Ta) and molybdenum (Mo). The capacitor electrode **112** may be a part of a power line (not shown). The second polycrystalline pattern **105** and the capacitor electrode **112** overlapping the second active layer **105** constitute a storage capacitor with the interlayer insulating layer **110** interposed therebetween.

[0049] In FIGS. **7B** and **8B**, a fourth insulating layer **114** may be formed on the entire surface of the first substrate **100** covering the capacitor electrode **112**. First, second and third contact holes **116**, **118** and **120** may be formed in the fourth insulating layer **114** exposing the drain region **104c**, the source region **104b**, and the capacitor electrode **112**, respectively.

[0050] In FIGS. **7C** and **8C**, source and drain electrodes **124** and **122** may be formed on the fourth insulating layer **114** by depositing and patterning one of chromium (Cr), molybdenum (Mo), tantalum (Ta) and tungsten (W). The source electrode **124** may contact the source region **104b** through the second contact hole **118**, and the drain electrode **122** may contact the drain region **104c** through the first contact hole **116**. A common electrode **126** also may be formed on the fourth insulating layer **114** within the peripheral region A. A fifth insulating layer **128** may be formed on the entire surface of the first substrate **100** covering the source and drain electrodes **124** and **122** and the common electrode **126**. Fourth, fifth and sixth contact holes **134**, **136** and **138** may be formed in the fifth insulating layer **128** exposing the drain electrode **122**, and the both sides of the common electrode **126**, respectively. Then, first and second connection electrodes **130** and **132** may be formed on the fifth insulating layer **128** by depositing and patterning a conductive metallic material. The first connection electrode **130** may contact the drain electrode **122** through the fourth contact hole **134** within the pixel region P. The second connection electrode **132** may contact the common electrode **126** through the fifth contact hole **136**.

[0051] FIGS. **9A** to **9D** are cross-sectional views showing an exemplary fabricating process for a display area of a second substrate for an organic electroluminescent device according to the present invention. FIGS. **10A** to **10D** are cross-sectional views showing an exemplary fabricating process for a peripheral region of the second substrate for an organic electroluminescent device according to the present invention. In FIGS. **9A** and **10A**, a second substrate **200** may include a plurality of pixel regions P in the display area, and a peripheral region A at one side of the display area. A plurality of first auxiliary electrodes **202** may be formed on the second substrate **200** by depositing and patterning a metallic material having relatively low resistance. The plurality of first auxiliary electrodes **202** may have a lower resistance than a first electrode to be formed thereon later. For example, if the first electrode is made of indium-tin-oxide, the plurality of first auxiliary electrodes **202** may be made of one of chromium, molybdenum, aluminum, and aluminum alloy. A second auxiliary electrode **203** may be formed on the second substrate within the peripheral region A. The first auxiliary electrodes **202** may have a lattice form. Since the first auxiliary electrodes **202** may be made of an opaque metallic material, the first auxiliary electrodes **202** are disposed at regions where light is not emitted, i.e., at outsides of the pixel region P for displaying images. The first

auxiliary electrodes **202** and the second auxiliary electrode **203** may be electrically connected at a certain place.

[0052] A first electrode **204** may be formed on an entire surface of the second substrate **200** covering the first auxiliary electrodes **202** and the second auxiliary electrode **203**. The first electrode **204** may function as an anode for injecting holes into an organic luminescent layer to be formed thereon later. For example, the first electrode **204** may include indium-tin-oxide (ITO) or indium-zinc-oxide (IZO) that is transparent and has high work function. The first electrode **204** may receive a common voltage through the second connection electrode **132** of FIG. **8C** at the peripheral region A.

[0053] In FIGS. **9B** and **10B**, a plurality of isolating patterns **206** may be formed on the first electrode **204** over the first auxiliary electrodes **202** by using an insulating material. The isolating patterns **206** may have a lattice form in a plan view. An insulating pattern **208** of an island shape, which is made of the same material as the isolating patterns **206**, may also be formed on the first electrode **204** over the second auxiliary electrode **203** within the peripheral region A. A plurality of partition walls **210**, which also have a lattice form, may be formed on the isolating patterns **206**. The plurality of partition walls **210** may be made of an insulating material including a photosensitive organic material. The plurality of partition walls **210** make a plurality of organic luminescent layers and a plurality of second electrodes to be separately formed by pixel regions P in the following processes.

[0054] In FIGS. **9C** and **10C**, a plurality of organic luminescent layers **212** may be formed on the first electrode **204** in the pixel regions P. The organic luminescent layer **212** emitting one of red, green and blue colors corresponds to each of the pixel regions P. The organic luminescent layer **212** has a single layer or multiple layers. When the organic luminescent layer **212** has multiple layers, the organic luminescent layer **212** may include a hole transporting layer (HTL) **212a** contacting the first electrode **204**, an organic emitting layer **212b** on the HTL **212a**, and an electron transporting layer (ETL) **212c** on the organic emitting layer **212b**.

[0055] In FIGS. **9D** and **10D**, a plurality of second electrodes **214** may be formed on the organic luminescent layers **212**. Each of the second electrodes **214** may correspond to each of the pixel regions P and may be separated from each other by the partition walls **210**. In addition, the isolating patterns **206** under the partition walls **210** may prevent the second electrodes **214** from electrically contacting the first electrode **204**. The plurality of second electrodes **214** may function as a cathode for injecting electrons into the organic luminescent layer **212**. A contacting electrode **216** may be simultaneously formed on the insulating pattern **208** within the peripheral region A in a process of forming the second electrode **214**. The contacting electrode **216** may contact the first electrode **204**. The contacting electrode **216** may connect to the second connection electrode **132** of FIG. **8C**, and may apply the common voltage to the first electrode **204** through the common electrode **126** and the second connection electrode **132** of FIG. **8C**. The second electrodes **214** and the contacting electrode **216** may include a single layer of aluminum (Al), calcium (Ca) or magnesium (Mg), or multiple layers of lithium fluoride (LiF) or aluminum

(Al). The plurality of second electrodes **214** may have a lower work function than the first electrode **204**.

[0056] The first and second substrates **100** and **200** formed by fabricating processes of FIGS. **6A** to **10D** may be attached to each other with a sealant, thereby an organic electroluminescent device obtained.

[0057] FIG. **11** is a cross-sectional view showing another exemplary organic electroluminescent device according to the present invention. In FIG. **11**, first and second substrates **300** and **400** may be attached to each other with a predetermined space therebetween by a sealant **500**. The first and second substrates **300** and **400** may have a plurality of pixel regions P, which constitute a display area, and peripheral regions A, which are disposed at both sides of the display area. A plurality of thin film transistors T and a plurality of array lines (not shown) may be formed on an inner surface of the first substrate **300**. In particular, each of the thin film transistors T may be disposed adjacent of each of the pixel regions P.

[0058] A plurality of first auxiliary electrodes **402** may be formed on an inner surface of the second substrate **400** and a first electrode **404** may be formed on the entire inner surface of the second substrate **400** covering the first auxiliary electrodes **402**. The first electrode **404** may function as an anode for injecting holes. In addition, a plurality of isolating patterns **406** made of an insulating material may be formed on the first electrode **404**, and a plurality of partition walls **410** may be formed on the plurality of isolating patterns **406** corresponding to borders between the thin film transistors T and the pixel regions P. Between the adjacent partition walls **410**, a plurality of organic luminescent layers **412** and a plurality of second electrodes **414** may be formed on the first electrode **404**. The plurality of second electrodes **414** may function as a cathode for injecting electrons. Each of the plurality of second electrodes **414** may electrically connect to each of the thin film transistors T through a first connection electrode **330**. That is, a plurality of first connection electrodes **330** may be first formed on the inner surface of the first substrate **300**, and the first substrate **300** may be attached to the second substrate **400**, such that the first connection electrodes **330** contact the second electrodes **414**, respectively.

[0059] Common electrodes **326a** and **326b** may be formed over the inner surface of the first substrate **300** within the peripheral regions A. In addition, second auxiliary electrodes **403a** and **403b** may be formed on the inner surface of the second substrate **400** within the peripheral region A, such that the first electrode **404** covers the second auxiliary electrodes **403a** and **403b**. The second auxiliary electrodes **403a** and **403b** may be made of the same material as the first auxiliary electrodes **402**. In addition, insulating patterns **408a** and **408b** may be formed on the first electrode **404** over the second auxiliary electrodes **403a** and **403b**, and contacting electrodes **416a** and **416b** may be formed on the insulating patterns **408a** and **408b** to be directly connected to the first electrode **404**. The contacting electrodes **416a** and **416b** may be simultaneously formed during the process of forming the plurality of second electrodes **414**. The contacting electrodes **416a** and **416b** may electrically connect to the common electrodes **326a** and **326b** through second connection electrodes **332a** and **332b**, respectively.

[0060] Accordingly, the first and second connection electrodes **330**, **332a** and **332b** maintain uniform gaps both in the

pixel regions P and the peripheral regions A. Also, since the organic electroluminescent device is a top emission type, a high aperture ratio can be obtained. Furthermore, since an array pattern including a thin film transistor and an organic luminescent layer are independently formed on an individual substrate, bad effects due to a fabricating process of the organic luminescent layer can be prevented, thereby improving a production yield. Moreover, since a second connection pattern is formed at a peripheral region to contact a first pad and a first electrode, inferiority due to a signal distortion can be prevented, thereby further improving the production yield.

[0061] It will be apparent to those skilled in the art that various modifications and variations can be made in the organic electroluminescent display panel device and the method of fabricating the same of the present invention without departing from the spirit or scope of the invention. Thus, it is intended that the present invention covers the modifications and variations of this invention provided they come within the scope of the appended claims and their equivalents.

What is claimed is:

1. An organic electroluminescent device, comprising:

first and second substrates facing and spaced apart from each other, the first and second substrates having a display area including a plurality of pixel regions and a first peripheral region at one side of the display area;

a first common electrode at the first peripheral region on an inner surface of the first substrate;

a driving thin film transistor at each of the pixel regions on the inner surface of the first substrate, the driving thin film transistor including an active layer, a gate electrode, and source and drain electrodes;

a first connection electrode connected to the drain electrode of the driving thin film transistor at each of the pixel regions;

a second connection electrode connected to the first common electrode at the first peripheral region;

a first electrode on an entire inner surface of the second substrate;

isolating patterns on the first electrode corresponding to each border between the pixel regions;

a first insulating pattern at the first peripheral region on the first electrode corresponding to the second connection electrode;

partition walls on the isolating patterns;

an organic luminescent layer at each of the pixel regions on the first electrode;

a second electrode on the organic luminescent layer connected to the first connection electrode at each of the pixel regions;

a first contacting electrode on the first insulating pattern contacting the first electrode; and

a sealant attaching the first and second substrates.

2. The device according to claim 1, further comprising a first auxiliary electrode and a second auxiliary electrode between the second substrate and the first electrode, wherein

the first auxiliary electrode corresponds to the isolating patterns and the second auxiliary electrode corresponds to the first insulating pattern.

3. The device according to claim 1, wherein the first insulating pattern includes a same material as the isolating patterns.

4. The device according to claim 1, wherein the second connection electrode includes a same material as the first connection electrode.

5. The device according to claim 1, wherein the first contacting electrode includes a same material as the second electrode.

6. The device according to claim 1, wherein the active layer includes polycrystalline silicon.

7. The device according to claim 1, further comprising a power line connected to the driving thin film transistor.

8. The device according to claim 7, further comprising a capacitor electrode overlapping the power line to a storage capacitor.

9. The device according to claim 1, wherein the first electrode is an anode for injecting holes into the organic luminescent layer and the second electrode is a cathode for injecting electrons into the organic luminescent layer.

10. The device according to claim 9, wherein the first electrode includes one of indium-tin-oxide (ITO) and indium-zinc-oxide (IZO).

11. The device according to claim 9, wherein the second electrode includes one of calcium (Ca), aluminum (Al) and magnesium (Mg).

12. The device according to claim 1, wherein the first common electrode is disposed at an interior of the sealant.

13. The device according to claim 1, further comprising a second common electrode on the inner surface of the first substrate, a third connection electrode connected to the second common electrode, a second insulating pattern on the first electrode, and a second contacting electrode on the second insulating pattern, wherein the second common electrode, the third connection electrode, the second insulating pattern and the second contacting electrode are disposed at a second peripheral region at another side of the display area, and the second contacting electrode contacts the first electrode and connects to the third connection electrode.

14. The device according to claim 13, further comprising a first auxiliary electrode, a second auxiliary electrode and a third auxiliary electrode between the second substrate and the first electrode, wherein the first auxiliary electrode corresponds to the isolating patterns, the second auxiliary electrode corresponds to the first insulating pattern, and the third auxiliary electrode corresponds to the second insulating pattern.

15. A method of fabricating an organic electroluminescent device, comprising:

forming an insulating layer on a first substrate having a display area including a plurality of pixel regions and a first peripheral region at one side of the display area;

forming a driving thin film transistor at each of the plurality of pixel regions on the insulating layer, the driving thin film transistor including an active layer, a gate electrode, and source and drain electrodes;

forming a first common electrode at the first peripheral region on the insulating layer;

forming a first connection electrode and a second connection electrode, the first connection electrode connected to the drain electrode, the second connection electrode connected to the first common electrode;

forming a first electrode on a second substrate;

forming isolating patterns and a first insulating pattern on the first electrode, the isolating patterns corresponding to each border between the pixel regions, the first insulating pattern at the first peripheral region;

forming partition walls on the isolating patterns;

forming an organic luminescent layer at each of the plurality of pixel regions on the first electrode;

forming a second electrode on the organic luminescent layer;

forming a first contacting electrode on the first insulating pattern and contacting the first electrode; and

attaching the first and second substrates with a sealant such that the first connection electrode contacts the second electrode and the second connection electrode contacts the first contacting electrode.

16. The method according to claim 15, further comprising a step of forming a first auxiliary electrode and a second auxiliary electrode between the second substrate and the first electrode, wherein the first auxiliary electrode corresponds to the isolating patterns and the second auxiliary electrode corresponds to the first insulating pattern.

17. The method according to claim 16, wherein the first and second auxiliary electrodes have a lower resistance than the first electrode.

18. The method according to claim 17, wherein the first and second auxiliary electrodes includes one of chromium (Cr), molybdenum (Mo) and tungsten (W).

19. The method according to claim 15, wherein the step of forming a first contacting electrode is simultaneously performed with the step of forming a second electrode.

20. The method according to claim 15, wherein the first electrode is an anode for injecting holes into the organic luminescent layer, and wherein the second electrode is a cathode for injecting electrons into the organic luminescent layer.

21. The method according to claim 20, wherein the first electrode includes one of indium-tin-oxide (ITO) and indium-zinc-oxide (IZO).

22. The method according to claim 20, wherein the second electrode includes one of calcium (Ca), aluminum (Al) and magnesium (Mg).

23. The method according to claim 15, further comprising steps of forming a polycrystalline silicon pattern connected to the gate electrode and forming a capacitor electrode over the polycrystalline silicon pattern constituting a storage capacitor, the capacitor electrode being connected to the drain electrode.

24. The method according to claim 15, wherein the first common electrode is disposed at an interior of the sealant.

25. The method according to claim 15, further comprising steps of:

forming a second common electrode on the inner surface of the first substrate;

forming a third connection electrode connected to the second common electrode;

forming a second insulating pattern on the first electrode;
and

forming a second contacting electrode on the second
insulating pattern,

wherein the second common electrode, the third connection
electrode, the second insulating pattern and the
second contacting electrode are disposed at a second
peripheral region at the other side of the display area,
and the second contacting electrode contacts the first
electrode and is connected to the third connection
electrode.

26. The method according to claim 25, further comprising
a step of forming a first auxiliary electrode, a second
auxiliary electrode and a third auxiliary electrode between
the second substrate and the first electrode, wherein the first
auxiliary electrode corresponds to the isolating patterns, the
second auxiliary electrode corresponds to the first insulating
pattern, and the third auxiliary electrode corresponds to the
second insulating pattern.

27. A method of fabricating an organic electroluminescent
device, comprising:

forming a first insulating layer on a first substrate having
a display area including a plurality of pixel regions and
a first peripheral region at one side of the display area;

forming an active layer on the first insulating layer at each
of the plurality of pixel regions, the active layer including
polycrystalline silicon, the active layer having
source and drain regions;

forming a second insulating layer on the active layer;

forming a gate electrode on the second insulating layer
over the active layer;

forming a third insulating layer on the gate electrode, the
third insulating layer having first and second contact
holes, the first contact hole exposing the source region,
the second contact hole exposing the drain region;

forming source and drain electrodes and a first common
electrode on the third insulating layer, the source electrode
being connected to the source region through the
first contact hole, the drain electrode connected to the
drain region through the second electrode, the first
common electrode disposed at the peripheral region;

forming a fourth insulating layer on the source and drain
electrodes and the first common electrode, the fourth
insulating layer having third, fourth and fifth contact
holes, the third contact hole exposing the drain electrode,
the fourth and fifth contact holes exposing the
first common electrode;

forming first and second connection electrodes on the
fourth insulating layer, the first connection pattern

connected to the drain electrode through third contact
hole, the second connection electrode connected to the
first common electrode through the fourth contact hole;

forming a first electrode on a second substrate;

forming isolating patterns and a first insulating pattern on
the first electrode, the isolating patterns corresponding
to each border between the pixel regions, the first
insulating pattern at the first peripheral region;

forming partition walls on the isolating patterns;

forming an organic luminescent layer at each of the
plurality of pixel regions on the first electrode;

forming a second electrode on the organic luminescent
layer;

forming a first contacting electrode on the first insulating
pattern and contacting the first electrode; and

attaching the first and second substrates with a sealant
such that the first connection electrode contacts the
second electrode and the second connection electrode
contacts the first contacting electrode.

28. The method according to claim 27, further comprising
steps of:

forming a second common electrode on the inner surface
of the first substrate;

forming a third connection electrode connected to the
second common electrode;

forming a second insulating pattern on the first electrode;
and

forming a second contacting electrode on the second
insulating pattern,

wherein the second common electrode, the third connection
electrode, the second insulating pattern and the
second contacting electrode are disposed at a second
peripheral region at the other side of the display area,
and the second contacting electrode contacts the first
electrode and is connected to the third connection
electrode.

29. The method according to claim 28, further comprising
a step of forming a first auxiliary electrode, a second
auxiliary electrode and a third auxiliary electrode between
the second substrate and the first electrode, wherein the first
auxiliary electrode corresponds to the isolating patterns, the
second auxiliary electrode corresponds to the first insulating
pattern, and the third auxiliary electrode corresponds to the
second insulating pattern.

* * * * *

专利名称(译)	有机电致发光显示面板装置及其制造方法		
公开(公告)号	US20040100191A1	公开(公告)日	2004-05-27
申请号	US10/716438	申请日	2003-11-20
[标]申请(专利权)人(译)	乐金显示有限公司		
申请(专利权)人(译)	LG.PHILIPS LCD CO. , LTD.		
当前申请(专利权)人(译)	LG DISPLAY CO. , LTD.		
[标]发明人	PARK JAE YONG		
发明人	PARK, JAE-YONG		
IPC分类号	H05B33/22 H01L27/32 H01L51/52 H01L51/56 H05B33/26 H05B33/00 H01J9/00 H01J9/24		
CPC分类号	H01L27/3246 H01L27/3251 H01L27/3276 H05B33/26 H01L51/56 H01L2251/5315 H01L51/5203		
优先权	1020020074012 2002-11-26 KR		
其他公开文献	US7064482		
外部链接	Espacenet USPTO		

摘要(译)

一种有机电致发光器件，包括具有像素区域和周边区域的第一和第二基板，在第一基板上的外围区域处的第一公共电极，在第一基板上的每个像素区域处的驱动薄膜晶体管（TFT），第一连接电极连接到TFT的漏电极，第二连接电极连接到第一公共电极，第一电极连接到第二基板，第一电极上的隔离图案对应于像素区域之间的每个边界，第一绝缘图案在对应于第二连接电极的第一电极上，隔离图案上的分隔壁，第一电极上的有机发光层，在每个像素区域处连接到第一连接电极的有机发光层上的第二电极，以及第一绝缘图案上的第一接触电极接触第一电极。

